METEOR

LSR36500

UNDERWATER
POOL
LIGHT



Operating Instructions

ASTEL
LIGHTING

CONTENTS

Preface	3
Features	3
Precautions	3
Components and Connectors	4
Installation	5
Controls	7
Appearance	8
Technical Specifications.....	8
Warranty.....	9
Declaration of Conformity.....	10



PREFACE

The METEOR LSR36500 series of a compact ultra-thin underwater pool light with built-in driver is designed to use the latest LED lighting technology.

The surface-mount designed casing enable very simple installation on the flat surface without any surface preparation during construction and the max. diameter of the hole through the wall is 8 mm.

The METEOR LSR36500 series is available in stainless steel casings. The lighting is available in white, blue, green or RGB colors with 36 high-power LEDs.

The multi-color RGB version allows changing of the color of lighting manually or automatically through the complete rainbow spectrum.

The most advanced electronic design with built-in microprocessor enables network connection and simple control of complete group of lights with dimming.

FEATURES

- Innovative Design
- Stainless Steel Casing
- 36 Power LEDs Design
- White, Blue, Green or Multi-Color RGB Lighting
- High Grade Polycarbonate Glass Optical Window
- Vacuum Metalized Reflector
- Remote Control
- Digital Dimming
- Polarity Protection
- Transient Protection
- Thermal Protection
- Low Power Consumption
- Simple Installation
- Optional accessories for different pools installations

PRECAUTIONS

- The underwater pool light has to be installed and used in accordance with the instructions of this manual only.
- The power supply has to be disconnected before installation.
- The underwater pool light is recommended to be installed around 0.2 m below the water line for the best illumination and to avoid over-heating.
- The optical window must be clear and not covered by any kind of isolating or other material.
- The optical window has to be cleaned with a mild soap or detergent and lukewarm water by using a soft cloth or sponge. Do not use abrasive or highly alkaline cleaners. Never scrape with razor blades or other sharp instruments. Benzene, leaded gasoline, acetone or carbon tetrachloride should never be used.
- Do not turn power off immediately and refer servicing to qualified service personnel if the underwater pool light does not operate normally following the operating instructions.

COMPONENTS AND CONNECTORS

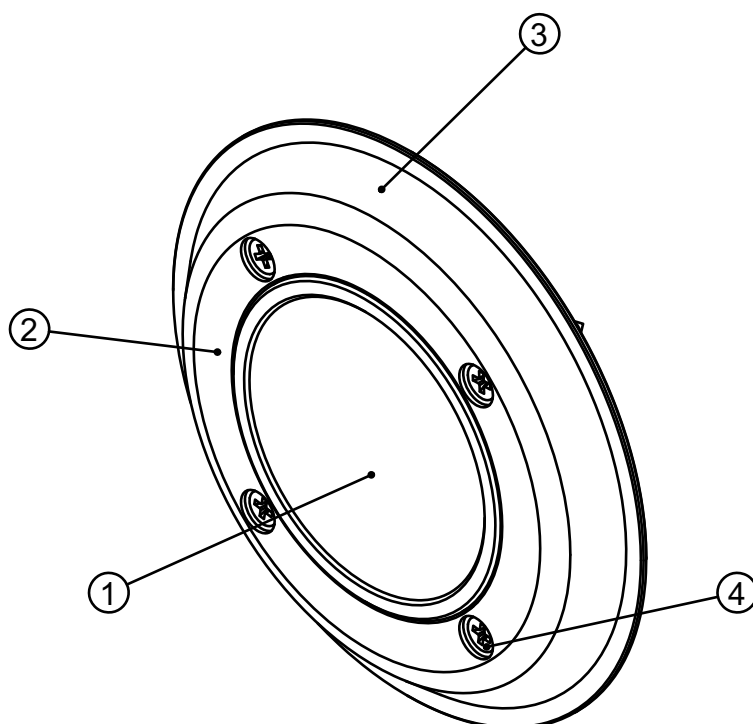

(1) Optical window

High-grade polycarbonate glass optical window.

(2) Underwater pool light casing

Stainless steel casing with fixing holes and cable gland.

(3) Cable

The 4-pole multi-core cable to connect the 24Vdc power supply and optional remote control or switch.

(4) Fixing screw

The fixing screws to fix the underwater pool light on the wall.

INSTALLATION

The underwater light kit consists of the following components:

- Underwater Light METEOR LSR36500
- 4 x fixing screw 5.5x50 with wallplugs
- Operating Instructions with Declaration of Conformity and Warranty conditions

The METEOR LSR36500 has to be installed on a flat surface on the pool wall under waterline. Do not try to install the underwater pool light while the pool is filled with water. When the installation is finished briefly test the underwater light prior to fill the pool with water. The installation have to be realized by a qualified personnel.

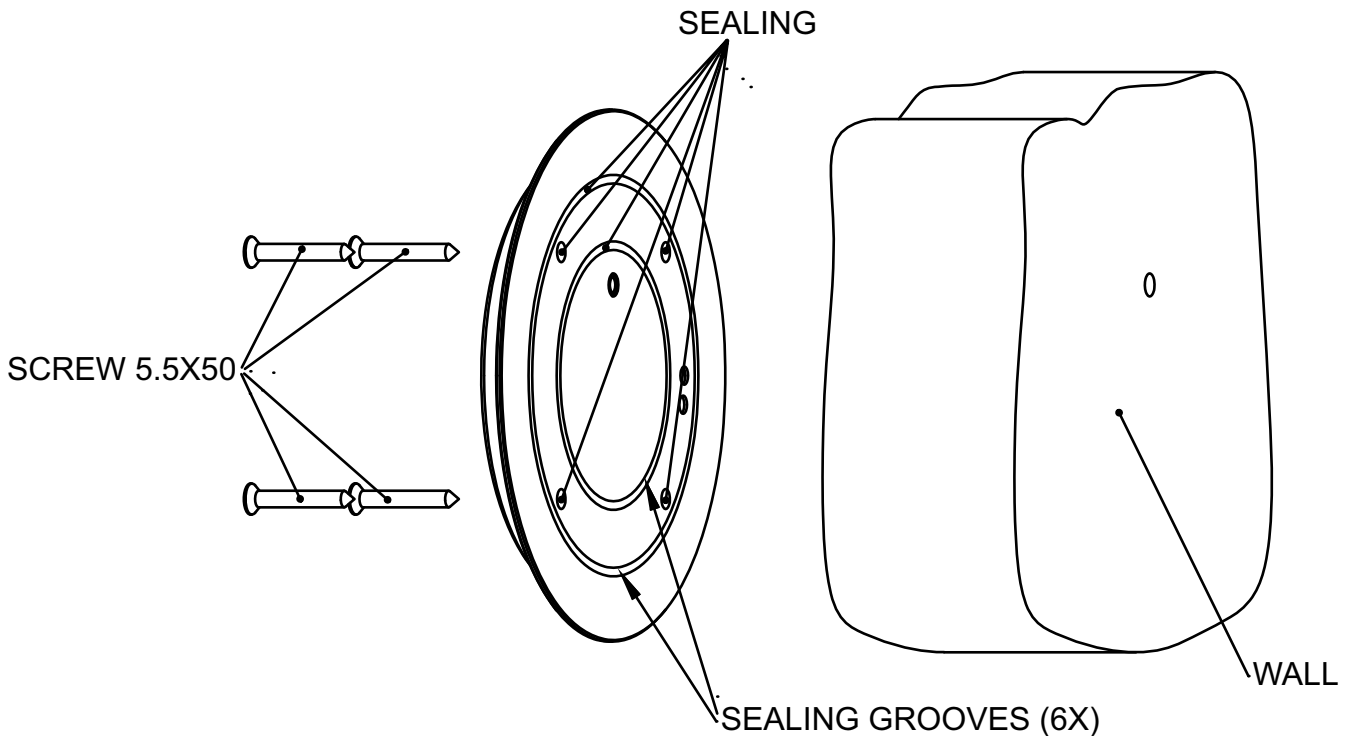

Note:

- ***Avoid using the underwater pool light out of the water for more than 1 minute. The underwater pool light is protected by a temperature sensor against over-heating. When the temperature of the underwater pool light exceeds 85°C the underwater pool light is automatically switched off.***

Wall preparation

The underwater pool light is recommended to be installed around 0.2 m below the waterline for the best illumination and to avoid over-heating.

To fix the underwater pool light with screws 5.5x50 the diameter of holes drilled into the wall has to be 8 mm.

The diameter of the hole for cable gland drilled through the wall has to be 8 mm.

Sealing

Before inserting the cable with gland through the hole the sealant has to be used into the grooves, around the four fixing holes and around the gland in the rear surface of the underwater pool light.

The sealant can be on silicon basis but the best solution is two-component polymer sealant.

Fixing

The underwater light has to be fixed with four screws 5.5x50 with wallplugs.

Note:

- ***Do not overtighten the screws as this can result in underwater pool light damage.***

Earthing

The underwater pool light has to be earthed by using a pre-tinned green wire with a yellow stripe a minimum of 8 AWG (8.36 mm²). The wire has to be connected to the underwater pool light by the help of one fixing screw 5.5x50.

Connection

The power supply has to be connected through the main switch (not included) with correct polarity and protected by a fuse (not included). The power supply voltage has to be 24Vdc.

Note:

- ***The power supply has to be switched off before installation.***

The underwater light has to be connected as described in the table below:

METEOR LSR36500 wire color	FUNCTION
Red	+ DC Power Supply
Black	GND Power Supply
Orange	+ Control
Brown	GND Control

Remote control connection

Single-color white (W), blue (B) or green (G) models

To remotely turn-on and turn-off the underwater pool light the simple switch (not included) can be used and connected to the CONTROL wires by a 2-pole signal cable (not included).

Note:

- ***If the remote control is not used at single-color models for normal operation the both CONTROL wires have to be bridged and insulated or connected to the GND.***

Multi-color (M) model

To control the mode of lighting the simple key-switch (not included) has to be used and connected to the CONTROL wires by the 2-pole signal cable (not included).

CONTROLS

Single-color white (W), blue (B) or green (G) models

Remote control can be used to turn-on and turn-off the underwater pool light and to control the luminosity.

Multi-color (M) model:

Remote control has to be used to turn-on and turn-off the underwater pool light and to control the mode of lighting and luminosity.

The multi-color underwater pool light can be controlled by using the key-switch.

When the light is turned-off the color or mode of lighting can be changed sequentially by pressing the momentary switch for 2 seconds:

METEOR LSR36500 Sequence of lighting
Custom Color
Full RGB
Cool White
Bluish White
Red
Green
Blue
Rainbow Color Spectrum

Turning on /off

Press the key-switch momentary.

Changing the color or mode of lighting

When the light is turned-off press the key-switch for 2 seconds.

Setting the Custom Color

At the selected Rainbow Color Spectrum mode press the key-switch momentary to turn the light off. After that press the key switch for 5 seconds or until the light is switched to the selected color and then the Custom Color is set and selected.

Dimming

When the light is turned-on press the key-switch until the desired illumination is achieved. By another pressing of the key-switch the luminosity will increase to the maximum illumination.

Set default

Press the key switch for min. 40 seconds or until the light is turned off.

Synchronization

When more than one multi-color underwater pool light is connected to the system the optional Synchronization Unit LSU08 is recommended to synchronize the colors of lighting at the Rainbow Color Spectrum mode of lighting. On the other case the colors of all installed lights would not be the same after few minutes or hours of operation in the Rainbow Color Spectrum mode.

If the multi-color light is used only with one of the fixed color of lighting the synchronization is not necessary.

APPEARANCE

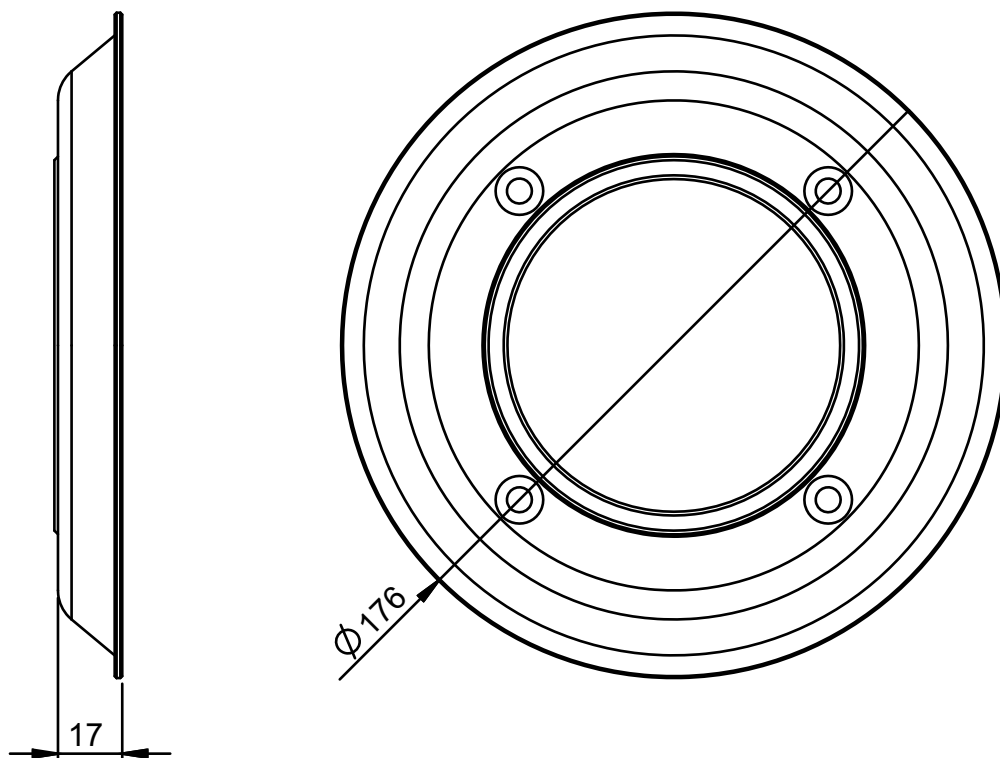

TECHNICAL SPECIFICATIONS

Power supply	24 Vdc, max. 3.4 A/24 Vdc
Lens angle	60°
Optical window	High-grade polycarbonate glass
Luminous flux	max. 7.000 lm
White color temperature	6.000 - 10.000 K
Operating temperature	-10°C - +40°C
Casing	Stainless steel (316L)
Protection	IP 68
Dimensions	$\varnothing 176$ x 17 mm
Weight	2.3 kg

Design and specifications subject to change without notice.

WARRANTY

1. The equipment manufactured by ASTEL d.o.o. is warranted to be free from defects in workmanship and materials under normal use and service.
2. This Warranty is in effect for of two years from the date of purchase by the user. Proof of purchase must be included, to establish that it is inside the warranty period.
3. This Warranty is transferrable and covers the product for the specified time period.
4. In case any part of the equipment proves to be defective, other than those parts excluded in paragraph 5 below, the owner should do the following:
 - (a) prepare a detailed written statement of the nature and circumstances of the defect, to the best of the Owner's knowledge, including the date of purchase, the place of purchase, the name and address of the installer, and the Purchaser's name, address and telephone number;
 - (b) the Owner should return the defective part or unit along with the statement referenced in the preceding paragraph to the warrantor, ASTEL d.o.o., or an authorized distributor, postage/shipping prepaid and at the expense of the Purchaser;
 - (c) if upon the Warrantor's or authorized distributor's examination, the defect is determined to result from defective material or workmanship, the equipment will be repaired or replaced at the Warrantor's option without charge, and returned to the Purchaser at the Warrantor's expense;
 - (d) no refund of the purchase price will be granted to the Purchaser, unless the Warrantor is unable to remedy the defect after having a reasonable number of opportunities to do so. Prior to refund of the purchase price, Purchaser must submit a statement in writing from a professional supplier that the installation instructions of the Operating Instructions manual have been complied with and that the defect remains;
 - (e) warranty service shall be performed only by the Warrantor, or an authorized distributor, and any attempt to remedy the defect by anyone else shall render this warranty void.
5. There shall be no warranty for defects or damages caused by faulty installation or hook-up, abuse or misuse of the equipment including exposure to excessive heat, salt or fresh water spray, or water immersion except for equipment specially designed as waterproof.
6. There shall be no responsibility or liability whatsoever on the part of the Warrantor or its employees and representatives for injury to any person or persons, or damage to property, loss of income or profit, or any other consequential or resulting damage or cost which may be claimed to have been incurred through the use or sale of the equipment, including any possible failure or malfunction of the equipment, or part thereof.

DECLARATION OF CONFORMITY

according to IEC Guide 22 and EN 45014

Manufacturer's Name: ASTEL, Podjetje za projektiranje, proizvodnjo in trgovino, d.o.o.

declares that the products

Item, Product Name and Model Number: 1. Underwater Pool Light METEOR LSR36500

conform to the following Product Specifications:

EMC: EN 55015:2006 + A1:2007
EN 61547:1995 + A1:2000 + A2:2009
EN 61547:2009

Safety: EN 60598-1:2004 + A1:2006

Supplementary Information:

The products herewith comply with the requirements of the following Directives and carry the CE-marking accordingly:

- the EMC Directive 2004/108/EC
- the Low Voltage Directive 2006/95/EC

29th November, 2011